

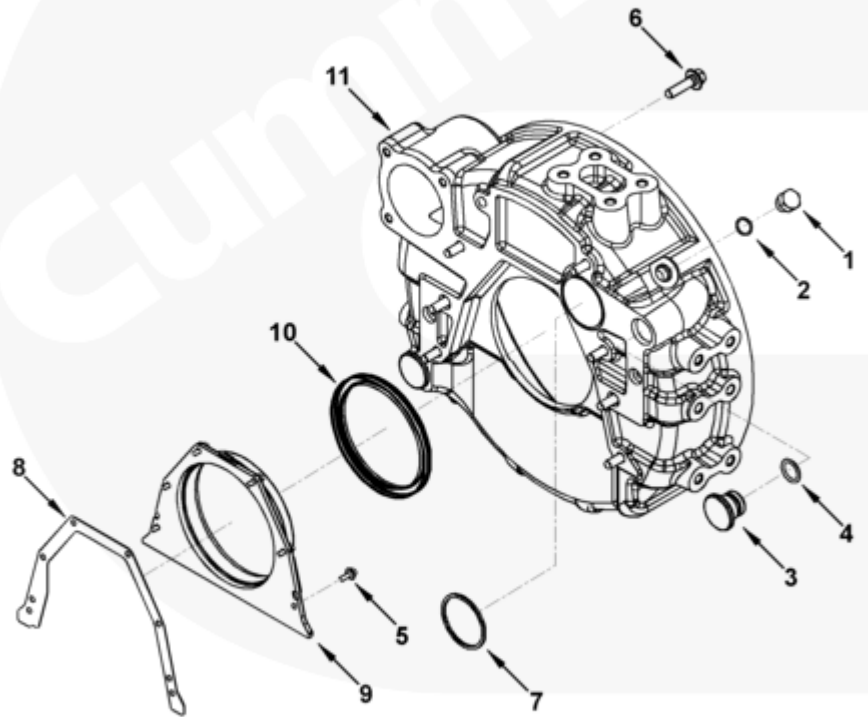

## Parts Catalog - Option Detail

Electronic Parts Catalog - Option Detail				
Option	Group	Graphic	Film Card	Date
FH9446-03	16.01	fh902zh	T	02-JUL-04
<b>Engines</b>	4B3.9, 6A3.4, 6B5.9, B GAS INTERNATIONAL CM556, B4.5, B4.5 CM2350 B129B, B4.5 CM2350 B146C, B4.5 CM2350 B147B, B4.5 RGT, B4.5S, B5.9 G, B5.9 GAS PLUS CM556, B5.9 LPG, B5.9 LPG PLUS CM556, B6.7 CM2350 B121B, B6.7 CM2350 B135B, B6.7 CM2350 B136C, B6.7 CM2350 B148B, B6.7 G CMOH6.0 B125, B6.7N CM2380 B150B, B6.7S, F3.8 CM2350 F120B, F3.8 CM2350 F128C, F3.8 CM2350 F132B, F3.8 F102, G3.9, G5.9, G5.9 CM558, ISB (CHRYSLER), ISB CM2150, ISB CM2150 E, ISB CM550, ISB CM850, ISB/ISD4.5 CM2150 B119, ISB/ISD4.5 CM2150 SN, ISB/ISD6.7 CM2150 B120, ISB/ISD6.7 CM2150 SN, ISB/ISD6.7 CM2880 B126, ISB3.9 CM2220 B107, ISB4.5 CM2150, ISB5.9G CM2180, ISB6.7 2010 DCX PICKUP, ISB6.7 2013 DCX CHASSIS CAB, ISB6.7 CM2150 SQ, ISB6.7 CM2250, ISB6.7 CM2350 B101, ISB6.7 CM2350 B103, ISB6.7 CM2350 B142, ISB6.7 CM2670 B153B, ISB6.7 G CM2180 B118, ISBE CM2150, ISBE CM800, ISBE2/ISBE3 CM850, ISBE4 CM850, ISD4.5 CM2150, ISD6.7 CM2880 D101, ISF2.8 CM2220, ISF2.8 CM2220 AN, ISF2.8 CM2220 EC, ISF2.8 CM2220 ECF2, ISF2.8 CM2220 F101, ISF2.8 CM2220 F117, ISF2.8 CM2220 F122, ISF2.8 CM2220 F126, ISF2.8 CM2220 F129, ISF2.8 CM2220 IAN, ISF3.8 CM2220, ISF3.8 CM2220 AN, ISF3.8 CM2220 F103, ISF3.8 CM2220 F110, ISF3.8 CM2220 F116, ISF3.8 CM2220 F134B, ISF3.8 CM2220 IAN, ISF3.8 CM2350 F109, ISF4.5 CM2220 F123, ISG11 CM2880 G106, ISG11 CM2880 G108, ISG12 CM2880 G107, ISG12 CM2880 G109, ISG12 G CMOH6.0 G111, QSB3.9 30 CM550, QSB3.9 CM2880 B138, QSB4.5 30 CM550, QSB4.5 CM2150 B108, QSB4.5 CM2250 B131, QSB4.5 CM2250 EC, QSB4.5 CM2350 B106, QSB4.5 CM2350 B122			



fh902zh

SMALL | MEDIUM | LARGE

Cart	Ref No	Part Number	Part Description	Required	Remarks
View My Cart					
		<a href="#">FH9446-03</a>	Flywheel Housing		<a href="#">Flywheel Housing...(More)</a>
					Item Supplied: Flywheel
					Housing
					Flywheel Housing SAE Size: 3
					Clutch Type: Dry
					Starter Bore Position: 49
					Flywheel to Block Mounting
					Pattern: 12 X M12 X 1.75
					Starter Motor Flange SAE

					Type: SAE #3 3 Bolt 120
					Starter Pilot Bore Dia: 88.9
					Starter Bore Horizontal
					Distance: -179.1
					Starter Bore Vertical
					Distance: 117.9
					Starter Bore Center Distance:
					214.4
					Starter Bore Angle From
					Horizontal CL: 49.1
					Tachometer Sensor Mounting
					Hole Count: 1
					Starter Mounting Hole Thread
					Size: M12
					Starter Mounting Face Offset:
					0
					Material: Aluminum
					Engine Mount Type: Pad
					Mounting Pad Hole
					Description: 6 X M12 X 1.75
					Mounting Pad Top Hole
					Location: 166
					Mounting Pad Angle: 0
					Transmission Mounting Hole
					Thread/Count: 12 X M10 X 1.5
					Tachometer Drive Location
					Size: Quad 4 3/4-16
					Engine Family: "B" Series
<input type="checkbox"/>		3045782	Threaded Plug	1	3/4 - 16 UNF.

<input type="checkbox"/>	1	<a href="#">3043556</a>	Threaded Plug	1	Purchase 3045782
<input type="checkbox"/>	2	<a href="#">3046201</a>	O-Ring Seal	1	
<input type="checkbox"/>	3	<a href="#">3910248</a>	O-Ring Plug	2	
<input type="checkbox"/>	4	<a href="#">3910260</a>	O-Ring Seal	2	
<input type="checkbox"/>	5	<a href="#">3991306</a>	Hexagon Flange Head Cap Screw	6	M8 x 1.25 x 15
<input type="checkbox"/>	6	<a href="#">3920447</a>	Hexagon Flange Head Cap Screw	8	M12 X 1.75 X 40.
<input type="checkbox"/>	7	<a href="#">3947328</a>	Rectangular Ring Seal	1	
<input type="checkbox"/>	8	<a href="#">3957492</a>	Rear Cover Gasket	1	
<input type="checkbox"/>		<a href="#">3967201</a>	Rear Cover	1	
<input type="checkbox"/>	9	<a href="#">3967200</a>	Rear Cover	1	
<input type="checkbox"/>	10	<a href="#">3970548</a>	Oil Seal	1	
<input type="checkbox"/>	11	<a href="#">3967356</a>	Flywheel Housing	1	

© 2019 Cummins Inc., Box 3005, Columbus, IN 47202-3005 U.S.A.  
Terms of Use and Disclaimers | Recommended System Requirements  
Need Assistance? Please click on the Contact Us button in the top right corner of any page.